

HERMETIC STRAIGHT MALE RECEPTACLE
SOLDER TYPE - FULL DETENT

R222.645.000

Series : SMP

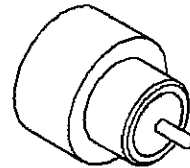
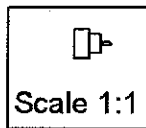
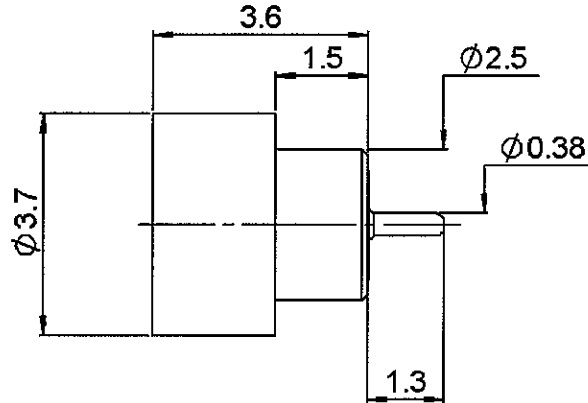

All dimensions are in mm.

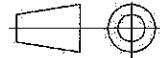

COMPONENTS	MATERIALS	PLATINGS (µm)
BODY	DILVER P1	GOLD 0.5 OVER NICKEL 2
CENTER CONTACT	DILVER P1	GOLD 0.5 OVER NICKEL 2
OUTER CONTACT		
INSULATOR	GLASS	
GASKET		
OTHERS PARTS		
-	-	-
-	-	-

Issue : 0530 B

In the effort to improve our products, we reserve the right to make changes judged to be necessary.



HERMETIC STRAIGHT MALE RECEPTACLE

R222.645.000

SOLDER TYPE - FULL DETENT

Series : SMP

PACKAGING

SPECIFICATION

Standard	Unit	Other
100	'W' option	Contact us

ELECTRICAL CHARACTERISTICS

ENVIRONMENTAL

Impedance		50 Ω
Frequency		0-18 GHz
VSWR	1.15 +	0.000 x F(GHz) Maxi
Insertion loss		0.12 √F(GHz) dB Maxi
RF leakage	-(NA - F(GHz)) dB Maxi
Voltage rating		335 Veff Maxi
Dielectric withstanding voltage		500 Veff mini
Insulation resistance		5000 MΩ mini

Operating temperature	-65/+165 ° C
Hermetic seal	10-8 Atm.cm ³ /s
Panel leakage	NA

OTHERS CHARACTERISTICS

Assembly instruction NA

Others :

MECHANICAL CHARACTERISTICS

Center contact retention	
Axial force – Mating end	6.8 N mini
Axial force – Opposite end	6.8 N mini
Torque	NA N.cm mini
Recommended torque	
Mating	NA N.cm
Panel nut	NA N.cm
Mating life	100 Cycles mini
Weight	0.220 g

Issue : 0530 B

In the effort to improve our products, we reserve the right to make changes judged to be necessary.



HERMETIC STRAIGHT MALE RECEPTACLE

R222.645.000

SOLDER TYPE - FULL DETENT

Series : SMP

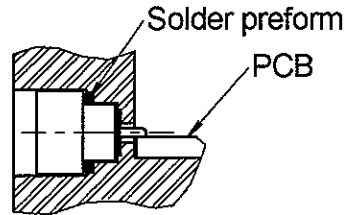

1. Degrease and clean connector and box
2. Solder the connector on the panel
we advise SnAg4 Cu0.5, we recommend a low residue flux.
Preheating at 100 °C. Take care not to exceed 260°C during solder operation
3. Solder the pin on the track
we advise SnAg4 Cu0.5, we recommend a low residue flux.
Preheating at 100 °C (only for ceramic substrate). Take care not to exceed 260°C during solder operation

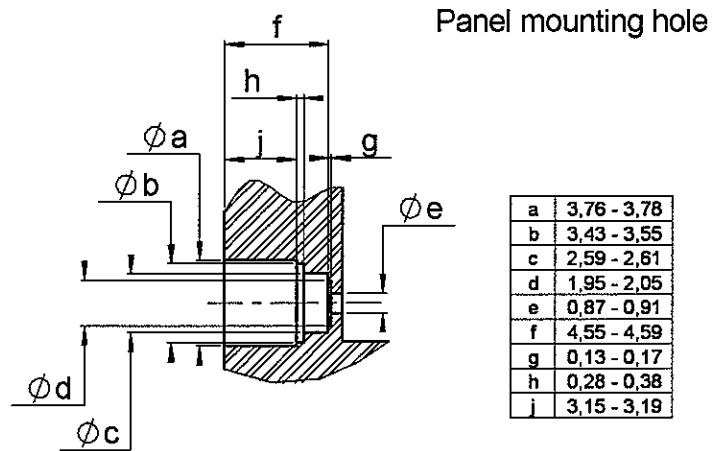

Issue : 0530 B

In the effort to improve our products, we reserve the right to make changes judged to be necessary.

